

Installation Instructions - 5000 Lt Underground Tank

1. Handling

- Move the tank by lifting, using the lifting lugs in the top
- Do not drop the tank.
- Do not roll it into the hole
- Do not drag tank across rough surfaces

2. Site Selection

- Must conform to local & statutory regulations
- Where no regulations exist, the distance of the excavation from any structure must be equal to or greater than twice the depth of the excavation. (Zone of influence)
- Must be located so that tree roots will not interfere with the tank or its associated fittings & plumbing.
- Must not be installed where there is a possibility of the water table exceeding half the height of the tank
- Must not be installed where actual or potential garden beds exist.
- Must not be installed where it will be subject to surcharge loading within 2m of the perimeter of the tank. This includes driveways, storage areas, anywhere stacked materials are placed, above ground pools & spas, high level residential footings, and anywhere that it is likely that people may congregate
- Placement of the tank is permitted adjacent to footings of residential dwellings so long as the designer of such footings maintains vertical support to these footings below the zone of influence of the tank as per local council requirements.
- Note that the tank in this form does not have the ability to withstand significant surcharge loads placed above the tank (and within the zone of influence such as stacked / material and multiple human access).

3. Excavation

- Observe any local and statutory requirements for excavations (eg benching/battering/shoring)
- Hole must be 2550 deep (measured from the finished ground level, not necessarily the existing ground level).
- The installer shall take all reasonable precautions to ensure that the tank is not within the zone of influence of nearby existing structures, such as retaining walls, residential dwellings, commercial buildings, and the like. In such circumstances, advice from a suitably qualified structural engineer should be obtained.
- At the top, the hole must be a minimum of 4.2 metres long by 4 metres wide.

See Figure 1 below.

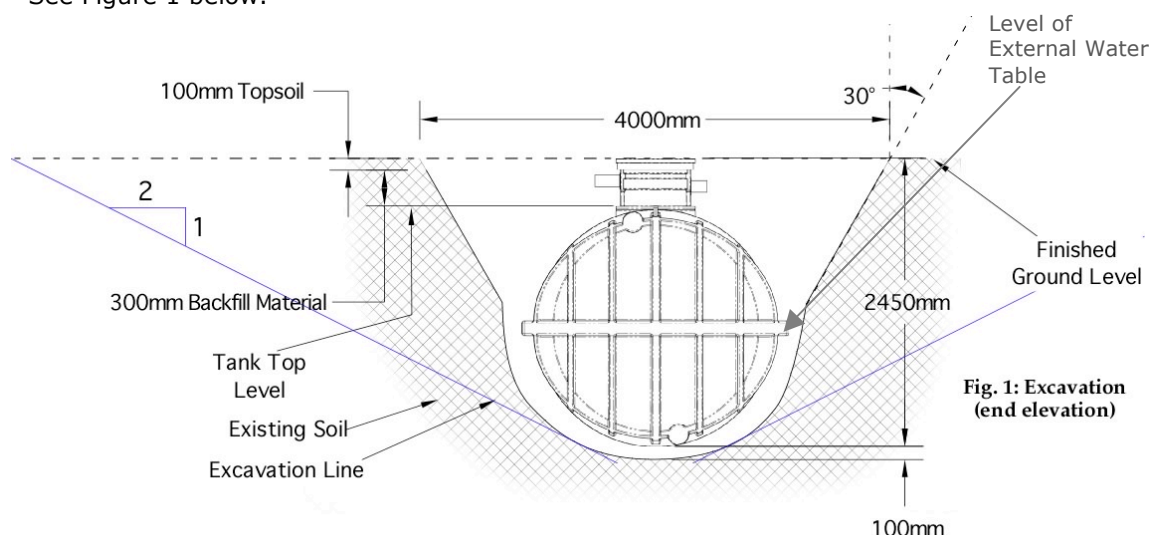

4. Placement of Tank

- Place the tank on a level bed of backfill material. This is to ensure that rocks & other debris in the excavation do not damage the tank.
- Ensure that the top of the tank is 400mm below the finished ground level.
- Fit the Riser to the tank:
- Ensure that the rim around the opening is clean and dry.
- Apply a 20mm bead of silicone to the groove in the rim around the opening.
- Place the riser in position with the bolt holes aligned with the threaded brass inserts. Ensure that the 2 flat faces are perpendicular to the inlet and outlet pipes.
- Bolt the riser into position using the supplied stainless steel bolts and washers.
- Fill tank with water to 30% capacity minimum prior to backfilling.

5. Backfilling

- Soil pressures based on a backfill/subgrade material with density of 18kN/m³
- Backfill material must have a minimum soil friction angle of 30°.
- Backfill material is to be compacted evenly around the perimeter of the tank to a minimum of 98% modified dry density $\pm 2\%$ optimum moisture content in compacted layers not greater than 200mm evenly around the tank during installation.
- Place fill slowly and evenly from both sides, and ensure that there are no voids, particularly underneath the hold down wings.
- Only hand held vibrating plate compactors may be used in the compaction process.
- Backfill cover over tank must be 400mm (300mm of backfill material and 100mm of topsoil is acceptable)
- Recommended backfill or foundation material is 10mm Blue metal or 10mm recycled concrete
- Ensure all caps and overflows are sealed prior to backfilling the excavation.
- Excessive dirt in the tank will cause line blockages and possible early pump failure.
- Connection pipes and couplings should be supported over the whole length of the trench.

See Figure 2 below.

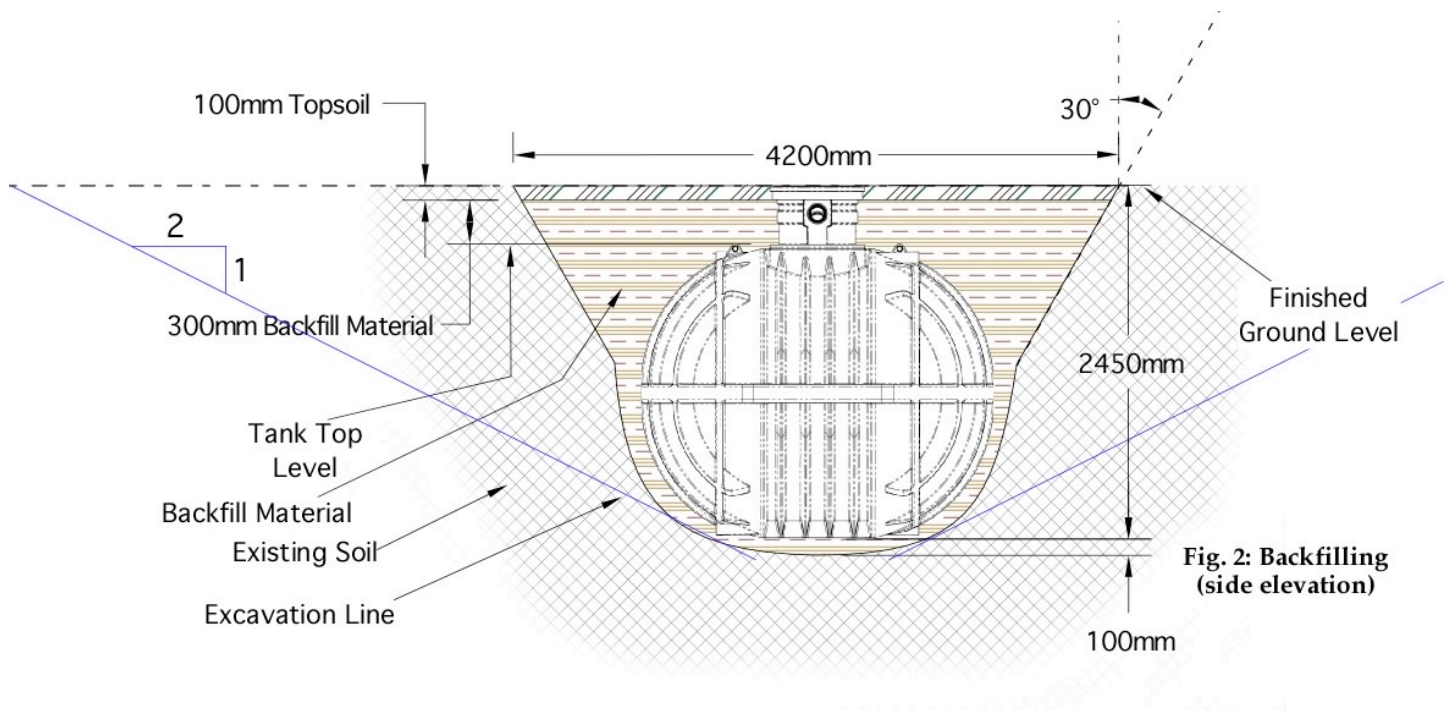

6. Riser Assembly

- When the finished height of the riser cover has been determined, the riser must be trimmed to the correct height:
- Cut the riser to 50mm below the finished height of the top of the cover, ensuring that the cut is square.
 - **If the riser is to be fitted without a leaf strainer basket (Fig. 3B):**
 - a. Proceed with (e) below.
 - **If the riser is to be fitted with a leaf strainer basket (Fig. 3A):**
 - b. Place the insert (bottom blue coloured ring in Fig 3A) into the riser, aligning the tabs with the slots in the riser. The insert will sit on a shoulder above the bottom of the riser.
 - c. Attach the insert to the riser using 4 of the supplied stainless steel tech screws.
 - d. Fit the strainer basket through the insert, and fix it to the insert using the 4 stainless steel self tapping screws (8g x 25mm) supplied.
 - e. Lay a 10mm bead of silicone sealant around the top of the riser, then place the riser end in place. This is secured using the 4 remaining stainless steel tech screws into the flat sections of the riser.
 - f. Using a hole saw, cut a Ø121mm hole at the appropriate height in the flat face one side of the riser for the inlet pipe. Note: In order to comply with AS/NZS 3500.2.2, it may be necessary to route the inlet pipe as shown in Fig. 3B.
 - g. Insert one of the supplied Wallace Seals into the hole.
 - h. Chamfer and lubricate the end of the pipe with a water based pipe jointing lubricant, then carefully push the pipe through the Wallace Seal without dislodging the seal.
 - i. Repeat steps c to e above for the overflow pipe.
 - j. Fit the lid and secure with 2 stainless steel socket cap screws (supplied).

An exploded view of the riser assembly is found in Figure 3 below.

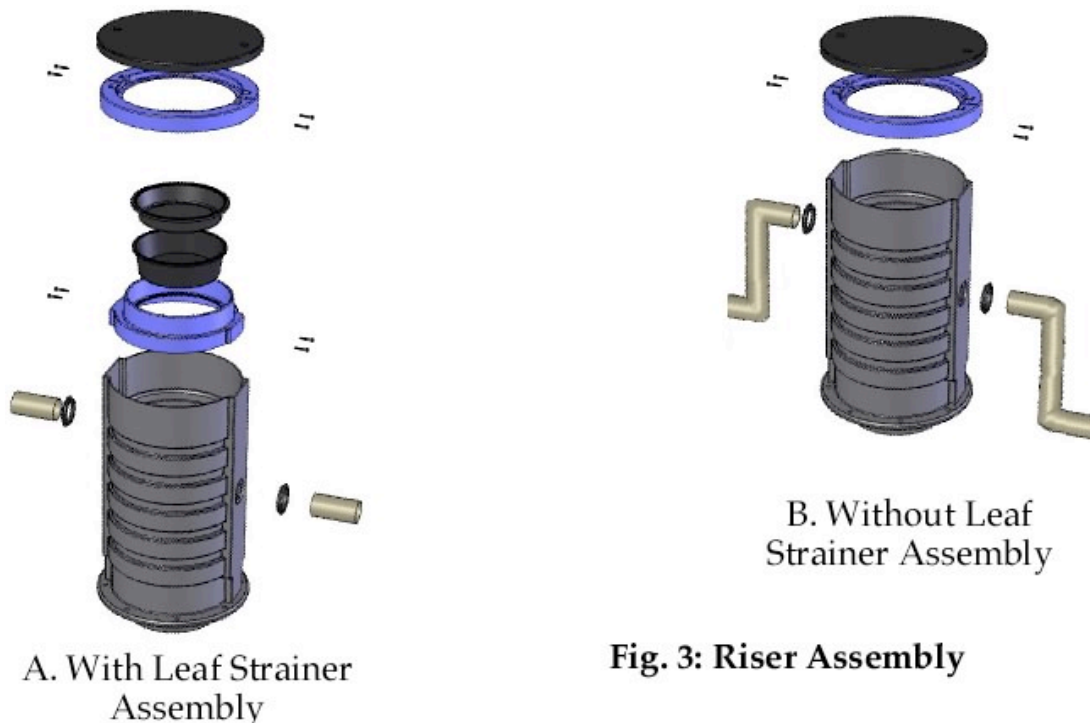

7. General

- The stored liquid is to have a specific gravity of 1.0 only.
- The maximum surcharge loading for a person traversing across the lid of the tank is 110 kg.

In addition to the above information we strongly recommend that the tank be kept at least 20% full of water in wet weather, or at any other time when the area around the tank may become waterlogged.